

ARX 36

LIGHT TANDEM VIBRATORY ROLLER Tier 4i



OPTIMUM COMPACTION OUTPUT

The Ammann ARX 36 Tandem Roller is an articulated ride-on roller that works flush against curbs and other obstructions to eliminate the need for special edge compaction efforts. Double drive and double vibration are standard and help deliver optimum compaction outputs of 50 kN. An electronic drive lever makes for smooth starting and stopping. High quality, long-lasting components reduce the cost of ownership over the lifetime of the machine.

COMPACTION PERFORMANCE

- Double drive
- Single or double vibration
- Optimal drum diameter
- Balanced weight front and rear
- 2 frequencies with 2 centrifugal forces

EASY MAINTENANCE

- Reliable, long-life vibration system
- Outside drain plugs for quick fluid changes
- Bearings and central articulated joint lubricated for the machine's life
- Easy access to maintenance points, water filters and nozzles
- Long service life and extended service intervals

EASY OPERATION

- Electronic drive lever for smooth starts and stops
- Rubber-mounted platform that limits vibration
- Intuitive, ergonomic instrument panel
- Tight turning radius

EXCELLENT VISIBILITY

- Unobstructed view to drums
- Sliding operator's seat

TRANSPORTABILITY

- Compact design for easy loading
- Light weight
- Foldable ROPS

REDUCED MATERIAL PICKUP

- Multiple water nozzles
- 2 scrapers per drum

APPLICATIONS

- Small and medium construction sites
- City roads
- Boardwalks
- Repair works in city centre

AMMANN

TECHNICAL SPECIFICATIONS
ARX 36 LIGHT TANDEM VIBRATORY ROLLER

DIMENSIONS

A	MACHINE LENGTH	2800 mm (110.2 in)
B	WHEELBASE	1950 mm (76.8 in)
C	MACHINE HEIGHT	2826 mm (111.3 in)
D	MACHINE HEIGHT (FOLDED ROPS)	2155 mm (84.8 in)
E	DRUM WIDTH	1300 mm (51.2 in)
E	TIRE-AXLE WIDTH	-
F	MACHINE WIDTH	1341 mm (52.8 in)
G	MACHINE LENGTH	2837 mm (111.7 in)
H	GROUND CLEARANCE	325 mm (12.8 in)
I	DRUM DIAMETER	850 mm (33.5 in)
J	DRUM SHELL THICKNESS	17 mm (0.7 in)
K	MACHINE WIDTH (TOTAL)	1423 mm (56 in)
L	MACHINE LENGTH (FOLDED ROPS)	2971 mm (117 in)

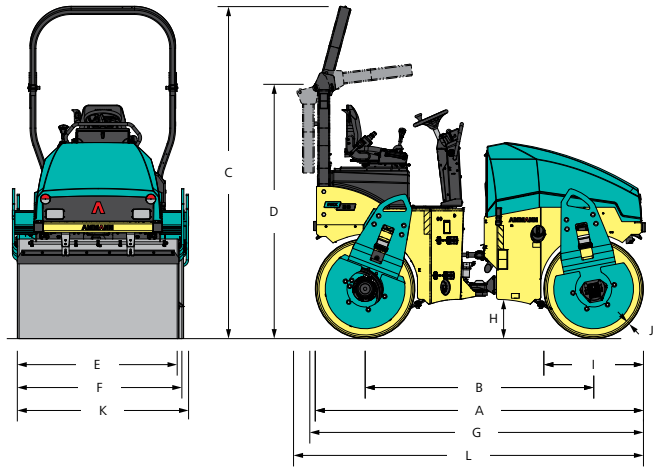

COMPACTION FORCES

AMPLITUDE	0.36/0.55 mm (0.01/0.02 in)
FREQUENCY AT 2100 / 2400 RPM	45/57 Hz (2700/3420 VPM)
CENTRIFUGAL FORCE – MAX.	50 kN

MISCELLANEOUS

BATTERY / CAPACITY	12/77 V/Ah
WATER TANK	350 l (92.5 gal)
HYDRAULIC TANK	37 l (9.8 gal)
DIESEL FUEL TANK	59 l (15.6 gal)
WHEEL LOAD	-
NUMBER OF WHEELS	-
TIRE SIZE	-

ENGINE

ENGINE TYPE	YANMAR 4TNV88
EMMISSION CLASS	EU Stage IIIA / EPA Tier 4i
POWER OUTPUT ISO 3046	30.0 kW / 40.8 HP
CYLINDER / LTR.	4 cyl / 2189 No./ccm
1. / 2. WORKING SPEED	2400 rpm
TRAVEL SPEED KM/H	10 km/h (6.2 MPH)
GRADEABILITY WITH / WITHOUT VIBR.	30 % / 40 %

WEIGHT AND OPERATING CHARACTERISTICS

OPERATING WEIGHT CECE	3725 kg (8212.2 lb)
OPERATING WEIGHT MAX.	4300 kg (9479.9 lb)
STATIC LINEAR LOAD (FULL-FLUSH)	14.3 kg/cm (31.5 lb)
TURNING RADIUS INSIDE	2581 mm (101.6 in)
STEERING / OSCILLATING ANGLE	32/8 ±°
DRUM OFFSET	40 mm (1.57 in)



STANDARD

- Front and rear vibration and drive
- Control system with emergency stop
- Pressurised pulse interval sprinkler system
- Ammann Vibration Control
- Lateral sliding seat
- 2 working frequencies / 2 amplitudes
- Hydraulic test ports

OPTIONAL EQUIPMENT

- CE-Kit with folding ROPS and working lights
- Road lighting
- Canopy
- Asphalt thermometer
- Reverse alarm
- Battery disconnection switch
- Central lifting hook
- ATC – Ammann Traction Control
- Arm rests
- Second drive-lever, left
- Edge-cutter incl. multi-function lever
- Bio-degradable hydraulic oil
- ACE^{force}
- Customer colour
- FOPS canopy
- Additional working lights (ROPS mounted)
- Warning beacon
- Foldable scrapers
- Weather canopy